

Agilent 85331B/85332B Solid State Switches

85331B SP2T 45 MHz to 50 GHz
85332B SP4T 45 MHz to 50 GHz
Technical Overview

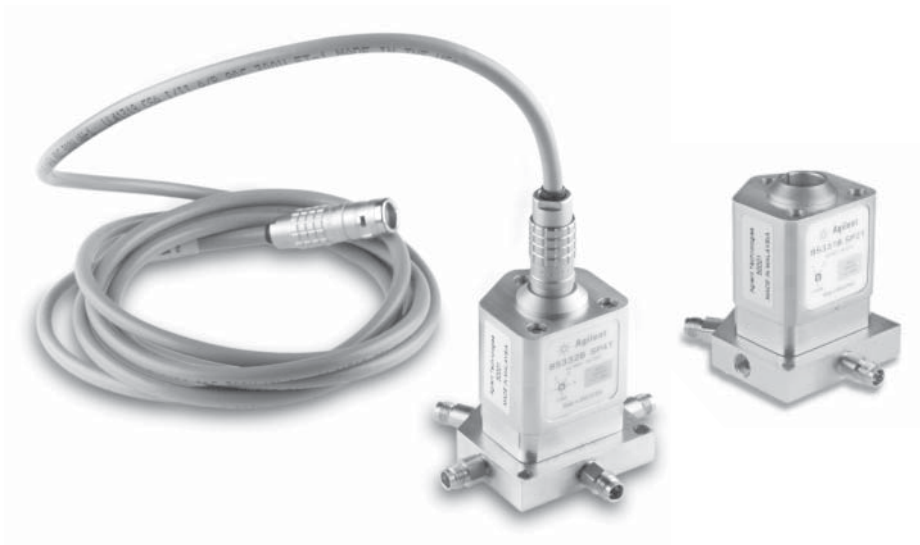

Key Features

- Maximizes your operating frequency range from 45 MHz up to 50 GHz
- Minimizes cross-talk with a high port-to-port isolation of above 90 dB
- Increases your switching speed, typically less than 1 μ s, suitable for high speed applications



Agilent Technologies

Description

The Agilent 85331B and 85332B are absorptive PIN diode solid state switches which provide superior performance in terms of high isolation and fast switching speed across a broad operating frequency range. The absorptive solid state switches are designed for high frequency, single- SP2T/SP4T operation and are extremely useful for applications in instrumentation, communications, radar, and many other test systems that require high speed RF & microwave switching.

The absorptive characteristic of the switches, provide a good impedance match, which is key to achieving accurate measurements.

Each output port has a PIN diode in series. The DC bias is used to turn on and off the pin diode depending on which port to select. There are some PIN diodes that shunt to ground in RF path, to improve the isolation of the switches.

Applications

Figure 1 shows a typical configuration with the PIN switches connected to the source antenna and antenna under test.

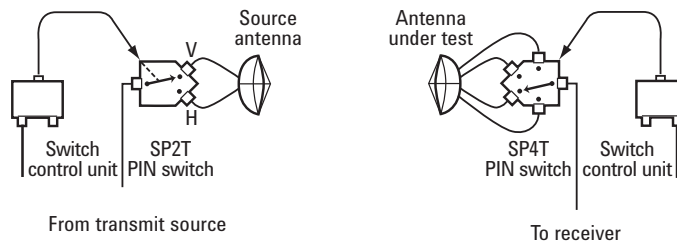

Figure 1. A typical multiple-channel, multiple frequency system configuration

Far-field antenna measurements

These products are ideally suited for antennas with multiple test ports, or applications that require measuring the co- and cross-polarization. One PIN switch can switch transmit polarization, and a second PIN switch can switch between the separate test ports of the antenna. With this technique, the co- and cross-polarization response of each test port can be measured in one rotation of the antenna.

Near-field antenna measurements

For near-field applications, both the co- and cross-polarized response of an antenna can be measured at multiple frequencies in a single scan across the antenna. For the dual polarized response, a PIN switch can be used to rapidly switch between the two probe polarizations.

Radar cross-section measurements

For Radar cross-section (RCS) applications, the ability to rapidly switch transmit and receive polarization allows full polarimetric RCS measurements to be made quickly and easily.

Complex switch configurations

Complex PIN switch trees with multiple outputs can be easily configured. Figure 2 shows conceptually how multiple PIN switches can be configured. Configurations such as these are used in making phased-array antenna measurements.

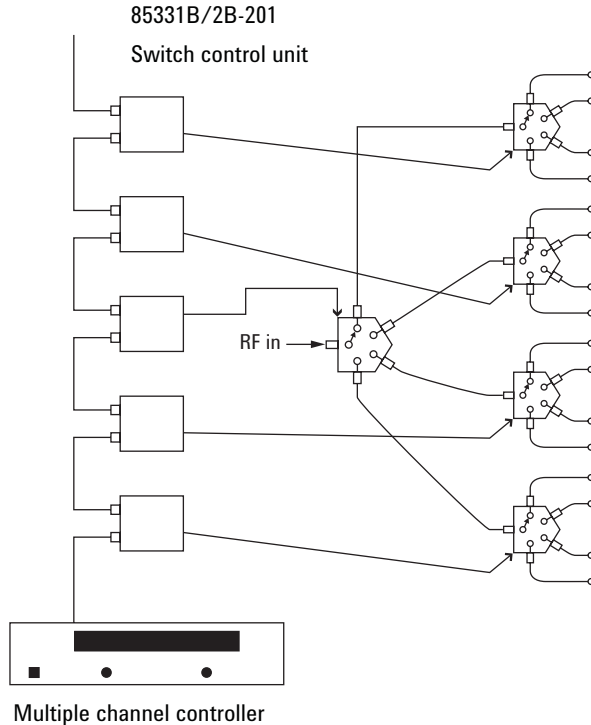

Figure 2. Example of a 1P16T switch configuration constructed from modular components

Specifications

Specifications refer to the performance standards or limits against which the PIN diode switches are tested.

Typical characteristics are included for additional information only and they are not specifications. These are denoted as “typical”, “nominal” or “approximate”.

Table 1. 85331/32B specifications

Model number	Frequency range (GHz)	Insertion loss (dB)	Isolation (dB)	Return loss (OFF port) (dB)	Return loss (ON port) (dB)	Return loss (COM port) (dB)
85331B SP2T	0.045 to 0.5	-2.0	-85	-19.0	-10.0	-10.0
	0.5 to 18	-4.5	-90	-19.0	-10.0	-10.0
	18 to 26.5	-6.0	-90	-12.5	-6.0	-5.5
	26.5 to 40	-10.0	-85	-10.0	-6.0	-4.5
	40 to 50	-15.5	-75	-6.0	-4.5	-4.0
85332B SP4T	0.045 to 0.5	-2.0	-85	-19.0	-9.0	-10.0
	0.5 to 18	-4.5	-90	-19.0	-9.0	-10.0
	18 to 26.5	-7.0	-90	-12.5	-5.0	-5.5
	26.5 to 40	-12.0	-85	-10.0	-4.5	-4.0
	40 to 50	-21.5 ¹	-75	-6.0	-4.5	-4.0

Typical switching speed: rise/fall time* 1.5 μs.

*Risetime is the time it takes for the detected RF output (measured using a square law detector) to raise from 10% to 90% of the final value, when a switch arm is changed from an “off” state to an “on” state. Falltime is the time it takes for the detected RF output (measured using a square law detector) to drop from 90% to 10% of the final value, when a switch arm is changed from an “on” state to an “off” state.

Table 2. Absolute maximum rating for 85331/32 B solid state switches

	Min	Nominal	Max	Unit
RF input power (average)			+27	dBm
Vdc bias turn on a port	-6.65	-7	-7.35	V
Current drawn for On port		40		mA
Vdc bias turn off a port	5.98	6.3	6.62	V
Current drawn for Off port		120		mA

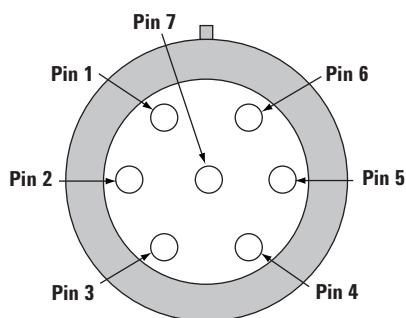

- Pin 1 = Port 1 on/off bias
- Pin 2 = Port 2 on/off bias
- Pin 3 = Port 3 on/off bias
(not connected for 85331B)
- Pin 4 = Port 4 on/off bias
(not connected for 85331B)
- Pin 5 = Common/ground (0VDC)
- Pins 6, 7 = Not connected

1. COM port-to-port 1 & 4.
2. COM port-to-port 2 & 3.

Figure 3. Bias connector pin locations

Specifications (continued)

Table 3. Biasing voltage configuration

	Port 1 Vbias	Port 2 Vbias	Port 3 Vbias	Port 4 Vbias	Current draw –ve supply	Current drawn +ve supply
Port 1 ON, other ports OFF	–7.0 V	+6.3 V	+6.3 V	+6.3 V	40 mA	360 mA
Port 2 ON, other ports OFF	+6.3 V	–7.0 V	+6.3 V	+6.3 V	40 mA	360 mA
Port 3 ON, other ports OFF	+6.3 V	+6.3 V	–7.0 V	+6.3 V	40 mA	360 mA
Port 4 ON, other ports OFF	+6.3 V	+6.3 V	+6.3 V	–7.0 V	40 mA	360 mA
All ports OFF	+6.3 V	+6.3 V	+6.3 V	+6.3 V	0 mA	480 mA

Note: Only ONE port can be ON at a time, all ports can be OFF at the same time.

Table 4. Typical current drawn

ON port	40 mA
OFF port	120 mA

Environmental Specifications

The 85331/32B switches are designed to fully comply with Agilent Technologies' product operating environment specifications. The following summarizes the environmental specifications for these products.

Temperature:

Operating	–20 °C to 55 °C
Storage	–40 °C to 70 °C
Cycling	–45 °C to 70°C, 10 cycles @ 20 °C per minute, 20 minutes dwell time per MIL-STD-833F, Method 1010.8, Condition C (modified)

Humidity:

Operating	5% to 95% at to +40 °C or less (non condensing)
Storage	5% to 95% at to +65 °C or less (non condensing)

Shock:

Half-sine, smoothed	100 G @ 6 ms, 3 shock pulses per orientation
---------------------	--

Vibration:

Broadband random	50 to 2000 Hz, 7.0 G rms, 15 minutes, per MIL-STD-833F, Method 2026-1 (modified)
------------------	--

Altitude:

Operating	< 4,600 meters (15,000 feet)
Storage	< 15,300 meters (50,000 feet)

ESD Immunity:

Contact discharge	15 kV (to outer conductor) per IEC 61000-4-2
Air discharge	6 kV (to center pin) per IEC 61000-4-2

Mechanical Dimensions

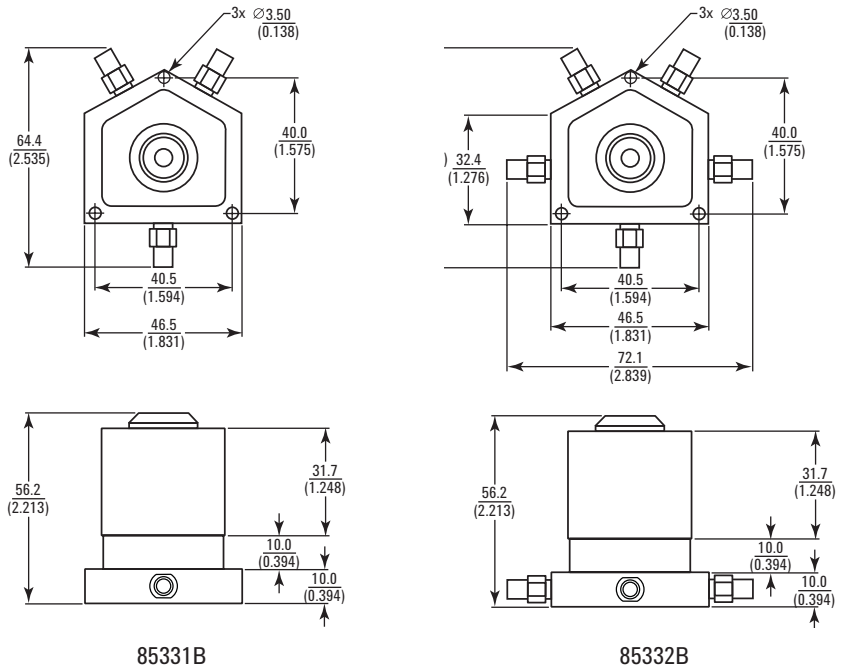

Figure 4. Product mechanical outline. Dimensions are in mm (inches) nominal, unless otherwise specified.

Size and weight:

57 mm (2.24") x 65 mm (2.56 mm) x 73 mm (2.88 mm) 0.36 kg (0.79 lbs)

Typical Performance 85331B

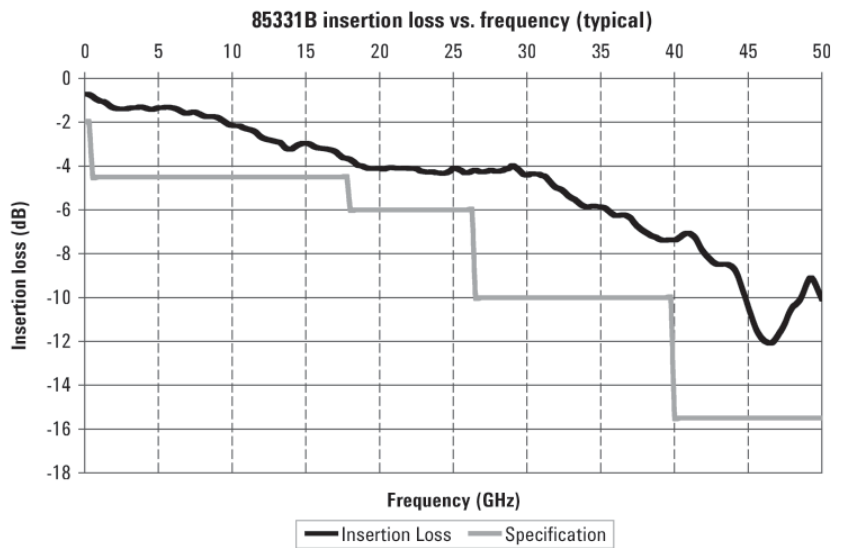

Figure 5. 85331B insertion loss vs. frequency (typical)

Typical Performance 85331B *(continued)*

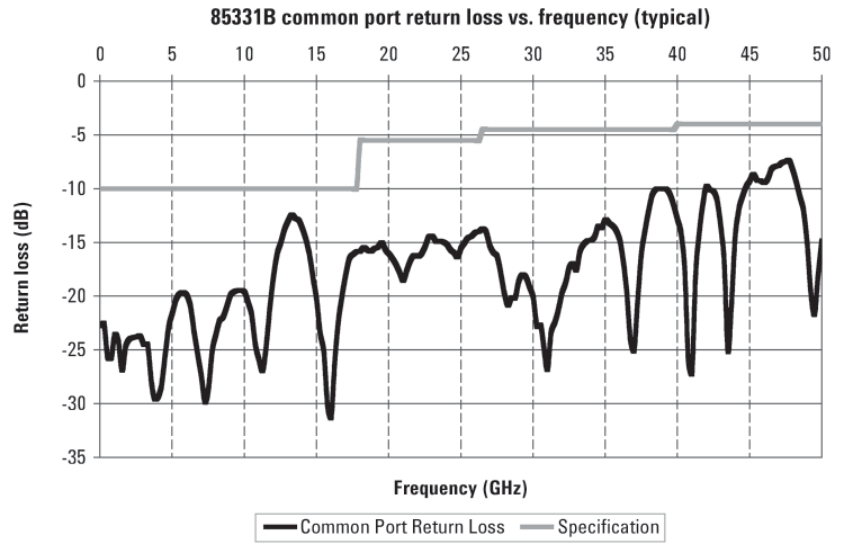

Figure 6. 85331B common port return loss vs. frequency (typical)

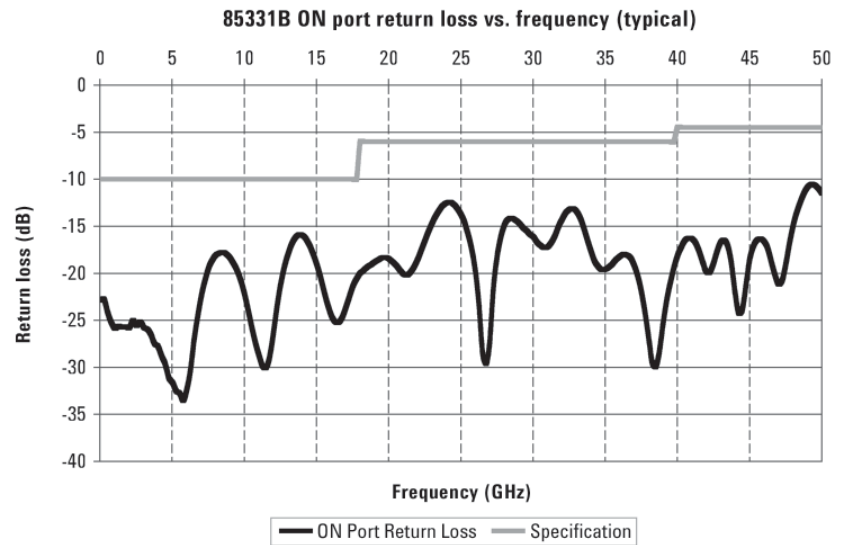

Figure 7. 85331B ON port return loss vs. frequency (typical)

Typical Performance 85331B *(continued)*

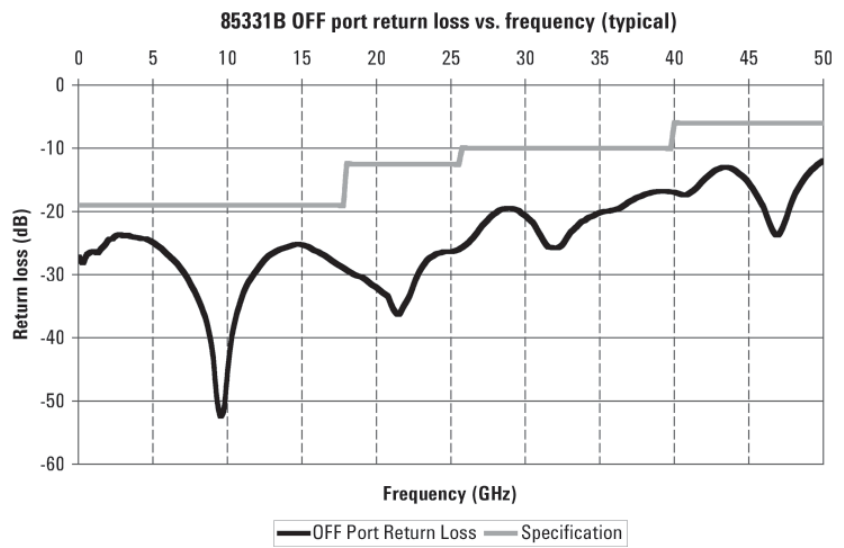

Figure 8. 85331B OFF port return loss vs. frequency (typical)

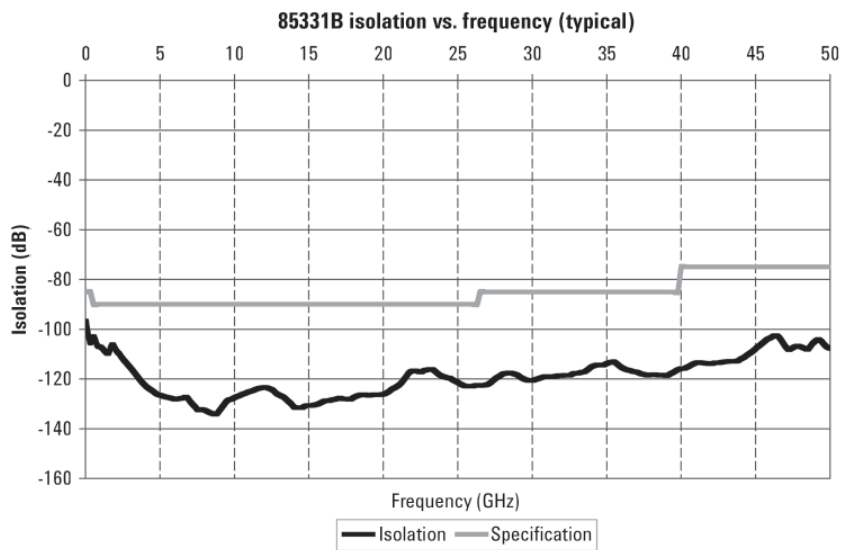

Figure 9. 85331B isolation vs. frequency (typical)

Typical Performance 85332B

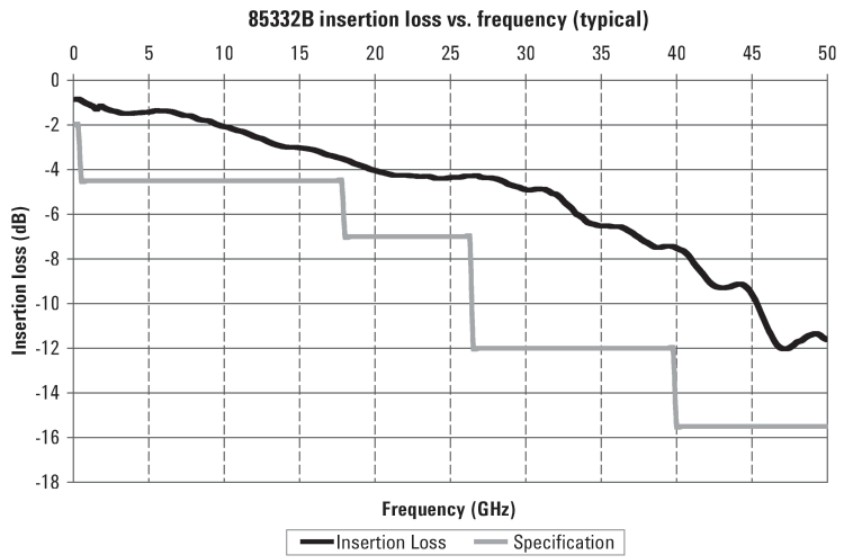

Figure 10. 85332B insertion loss vs. frequency (typical)

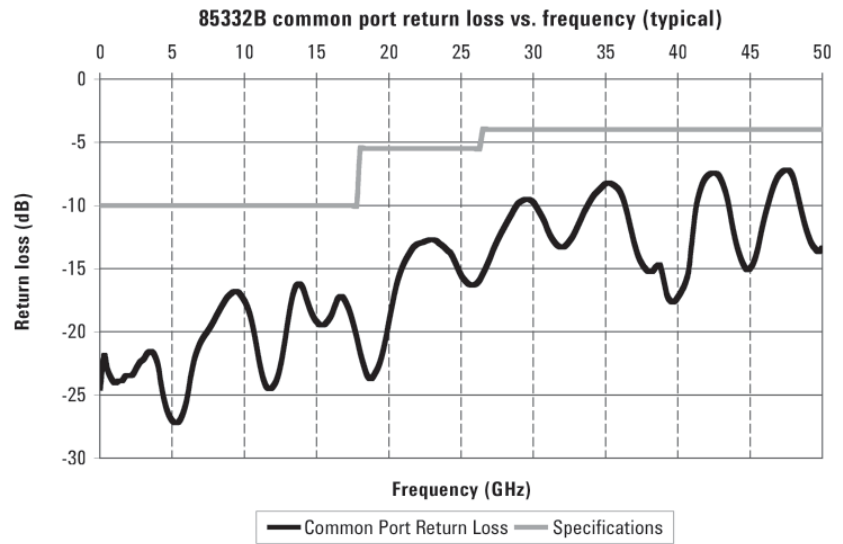

Figure 11. 85332B common port return loss vs. frequency (typical)

Typical Performance 85332B *(continued)*

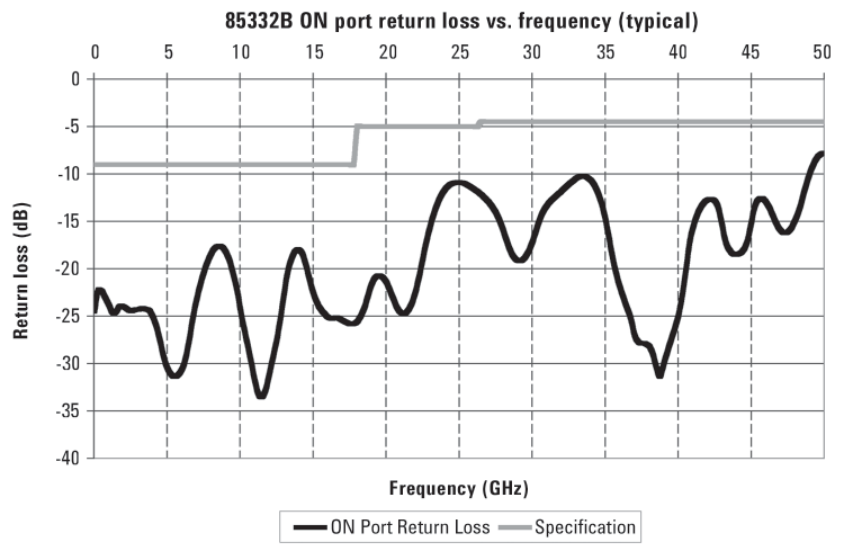

Figure 12. 85332B ON port return loss vs. frequency (typical)

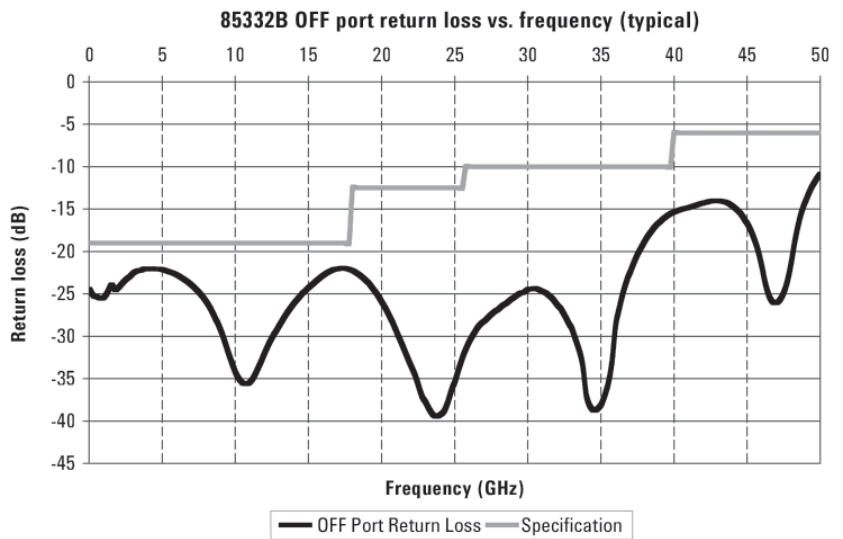

Figure 13. 85332B OFF port return loss vs. frequency (typical)

Typical Performance 85332B (continued)

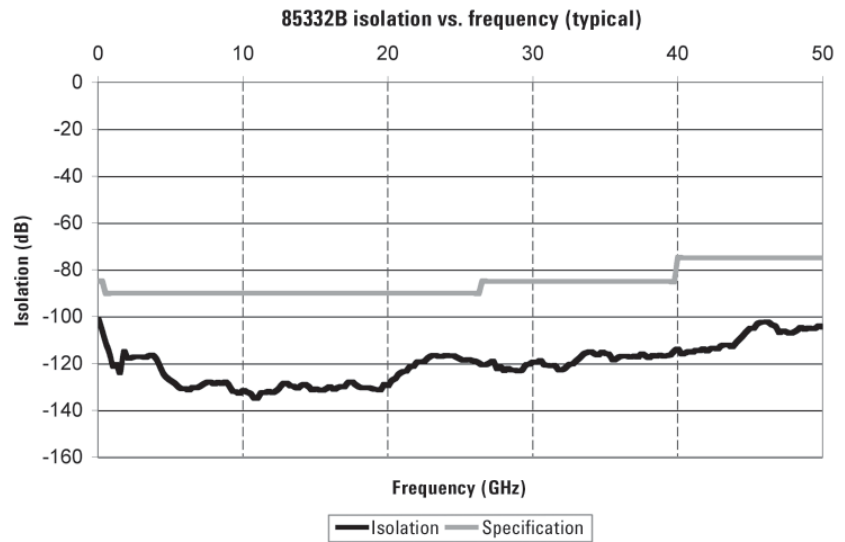

Figure 14. 85332B isolation vs. frequency (typical)

Ordering Information

85331B options	SP2T 45 MHz to 50 GHz solid state switch
85331B-001	Switch control cable - 1 meter
85331B-002	Switch control cable - 2 meter
85331B-005	Switch control cable - 5 meter
85331B-010	Switch control cable - 10 meter
85331B-015	Switch control cable - 15 meter
85331B-102	Switch control cable (one end bare wire) - 2 meter
85331B-115	Switch control cable (one end bare wire) - 15 meter
85331B-201	Switch control unit

85332B options	SP4T 45 MHz to 50 GHz solid state switch
85332B-001	Switch control cable - 1 meter
85332B-002	Switch control cable - 2 meter
85332B-005	Switch control cable - 5 meter
85332B-010	Switch control cable - 10 meter
85332B-015	Switch control cable - 15 meter
85331B-102	Switch control cable (one end bare wire) - 2 meter
85331B-115	Switch control cable (one end bare wire) - 15 meter
85332B-201	Switch control unit

Web Resource

<http://www.agilent.com/find/mta>

Related Literature

Publication title	Pub number
<i>N9397A/C Solid State Switches Flyer</i>	5989-3729EN
<i>N9397A/C Solid State Switches Technical Overview</i>	5989-4031EN
<i>Solid State Switches Application Note</i>	5989-5189EN
<i>Agilent Antenna Test Selection Guide</i>	5968-6759E



Agilent Email Updates

www.agilent.com/find/emailupdates
Get the latest information on the products and applications you select.



www.lxistandard.org
LXI is the LAN-based successor to GPIB, providing faster, more efficient connectivity. Agilent is a founding member of the LXI consortium.

Agilent Channel Partners

www.agilent.com/find/channelpartners
Get the best of both worlds: Agilent's measurement expertise and product breadth, combined with channel partner convenience.

Remove all doubt

Our repair and calibration services will get your equipment back to you, performing like new, when promised. You will get full value out of your Agilent equipment throughout its lifetime. Your equipment will be serviced by Agilent-trained technicians using the latest factory calibration procedures, automated repair diagnostics and genuine parts. You will always have the utmost confidence in your measurements. For information regarding self maintenance of this product, please contact your Agilent office.

Agilent offers a wide range of additional expert test and measurement services for your equipment, including initial start-up assistance, onsite education and training, as well as design, system integration, and project management.

For more information on repair and calibration services, go to:

www.agilent.com/find/removealldoubt

For more information on Agilent Technologies' products, applications or services, please contact your local Agilent office. The complete list is available at:

www.agilent.com/find/contactus

Americas

Canada	(877) 894-4414
Latin America	305 269 7500
United States	(800) 829-4444

Asia Pacific

Australia	1 800 629 485
China	800 810 0189
Hong Kong	800 938 693
India	1 800 112 929
Japan	0120 (421) 345
Korea	080 769 0800
Malaysia	1 800 888 848
Singapore	1 800 375 8100
Taiwan	0800 047 866
Thailand	1 800 226 008

Europe & Middle East

Austria	43 (0) 1 360 277 1571
Belgium	32 (0) 2 404 93 40
Denmark	45 70 13 15 15
Finland	358 (0) 10 855 2100
France	0825 010 700*
	*0.125 €/minute
Germany	49 (0) 7031 464 6333
Ireland	1890 924 204
Israel	972-3-9288-504/544
Italy	39 02 92 60 8484
Netherlands	31 (0) 20 547 2111
Spain	34 (91) 631 3300
Sweden	0200-88 22 55
Switzerland	0800 80 53 53
United Kingdom	44 (0) 118 9276201

Other European Countries:

www.agilent.com/find/contactus

Revised: October 1, 2009

Product specifications and descriptions in this document subject to change without notice.

© Agilent Technologies, Inc. 2006, 2009, 2010

Printed in USA, April 14, 2010
5989-4960EN

